

SUPER

VULCANO StarGold

PESO: kg 527

CONTENUTO D'ACQUA: litri 215

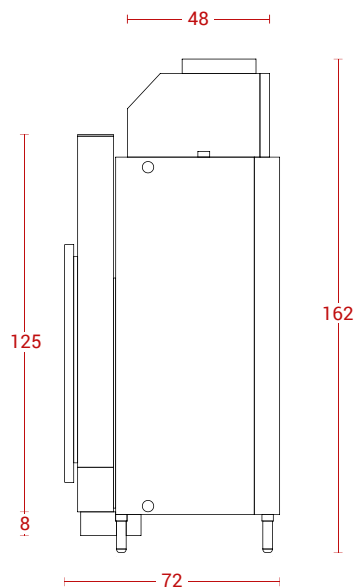

**VULCANO StarGold
SUPER 1**

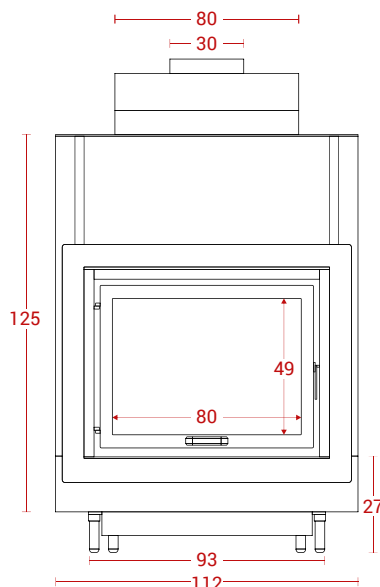

**VULCANO StarGold
SUPER 2**

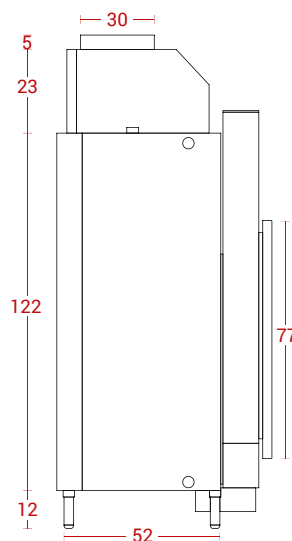

**VULCANO StarGold
SUPER 3**

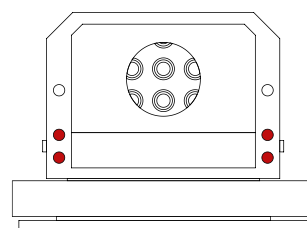
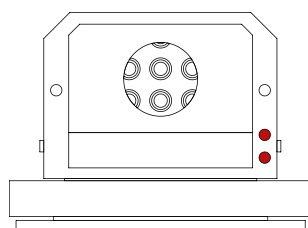
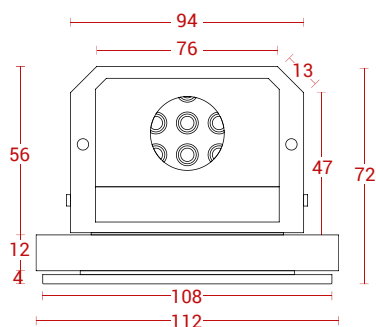

POTENZA TERMICA NOMINALE	RENDIMENTO	CLASSIFICAZIONE AMBIENTALE	CONTO TERMICO	CLASSE ENERGETICA
kw 29,6	88,4%	★★★★	Premialità 1,2	A ⁺